

Section Property Modules for British Standards: S.01_{BS} and S.06_{BS}

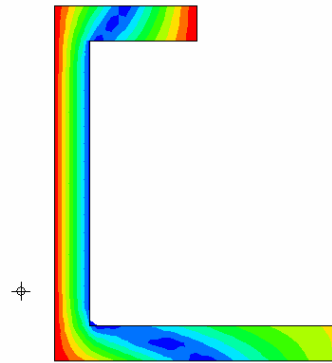
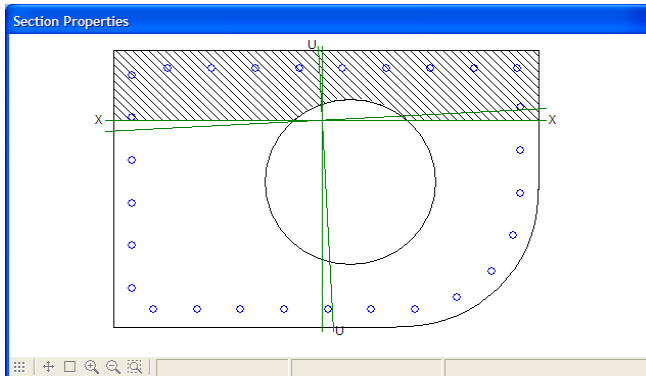

This is a set of two modules for general calculation of section properties, with special emphasis on the properties required by BS 5400 and BS 8110

S.01 – Section properties for any section

S.06 – Torsion and shear properties for any section

The section outline, voids, reinforcement and material properties are all defined in module S.01, which then calculates general section properties as well as those special properties required by BS 5400 and BS 8110.

Module S.01 is the basic building block of the Sam suite, because the sections it defines are used for code checking of reinforced concrete sections, and for defining cross sections of beams, which in turn are used to define longitudinal members of bridge decks.

Module S.06 calculates the torsion constant "C" using Prandtl's membrane analogy solved using finite difference equations. It is particularly powerful as it allows for continuous edges, as well as catering for any number of voids. It also calculates the shear properties for non-voided sections.

There are several benefits to these modules:

- ⇒ All numeric data is displayed graphically where possible, so that many errors of data entry are immediately obvious.
- ⇒ All results are displayed graphically, so that tables of numbers become meaningful pictures of results.
- ⇒ The modules use the same section data, so that changing between modules is completely seamless.
- ⇒ Wherever possible a mimic of an engineer's hand calculations are created, in order to allow the user to see why and how results are calculated. This allows the user to check the program, and to develop confidence in using it, as well as conforming to many quality standards that require a hard copy of the design calculations.

Module Specifications S.01 – Section properties for any section

Data Generation tools

- Graphical section generator containing shape libraries for:
 - Parametric shapes:
 - Rectangle, Circle, Annulus, Voided Slab, H, I, L, T, U, X, Z
 - Regular polygons
 - Standard pre-cast concrete beams:
 - Comprehensive libraries for UK, USA and Australian ranges.
 - Standard steel sections:
 - Comprehensive libraries for European (Arcelor) UK (BS4 and BS EN), USA (AISC), Australian (BHP) and Japanese ranges..
- Graphical section definer for sections comprising straight lines and arcs (no maximum number of nodes).
- Graphical section editor for building complex sections comprising unlimited number of individual shapes.
- Graphical reinforcement generator with unlimited number of reinforcing bars and pre-stressing tendons.
- Definition of tendon forces for use in modules S.04 and S.05.
- Graphical material properties definition from the following libraries:
 - Concrete to BS 5400 or BS 8110
 - Reinforcement to BS 5400 or BS 8110
 - Pre-stress tendons to BS 5400 (BS 8110 is identical)
 - Includes facilities for user defined partial factors for materials, E values and stress limitations.
 - User defined stress/strain relationships
 Section, bar and tendon data may be imported and/or exported using ASCII text files.

Basic Calculations

- Section property calculations for:
 - area – cross section area
 - i_{xx} , i_{yy} – second moments of area
 - i_{uu} , i_{vv} – ditto about principal axes
 - alpha – angle from global axes to principal axes
 - i_{xy} – product moment of inertia
 - \bar{x} , \bar{y} – centroid coordinates
- (For torsion properties see module S.06)
- The above properties are calculated for:
 - gross section
 - transformed section (to any E value)
 - net transformed section (BS 5400)
 - net transformed section (BS 8110)
 - plastic section
- Printer set-up for printing output for all modules
- Page heading set-up for printed and graphical output for all modules.
- Create user defined title block with user defined logo
- Add user notes to data file
- Option for changing units for input and output for all modules

Beam Module Calculations

When used in conjunction with module B.01, B.03 or B.04 this module also includes the necessary section property calculations. For module B.01 for example, these are:

- Effective Section - Concrete Flange
 - Effective breadth of concrete flange - sagging section
 - Effective breadth of concrete flange - hogging section
- Construction Stage (Steel beam only)
 - Elastic section properties
 Plastic section properties
- Composite Beam - Full Flange Width (No shear lag) - Sagging
 - Elastic section properties - short term E
 - Elastic section properties - long term E
 - Elastic section properties - long term E (shrinkage)
 - Plastic section properties
- Composite Beam - Full Flange Width (No shear lag) - Hogging
 - Elastic section properties
 - Plastic section properties
- Composite Beam - Effective Flange Width (Shear Lag) - Sagging
 - Elastic section properties - short term E
 - Elastic section properties - long term E
- Composite Beam - Effective Flange Width (Shear Lag) - Hogging
 - Elastic section properties
- Effective Section - Web
 - Effective web thickness - steel only
 - Effective web thickness - composite sagging section
 - Effective web thickness - composite hogging section
- Differential Temperature calculations as required:
 - BS 5400 Figure 9 (BD 37/88 Figure 9 is identical).
 - BS 5400 Appendix E (BD 37/88 Appendix E is identical).

Module Specifications S.06 – Torsion properties and shear calculations for any section

- For sections defined using module S.01:
 - Calculation of the torsion constant "C" using Prandtl's membrane analogy solved using finite difference equations.
 - Calculation of the maximum torsion stress.
 - Calculation of the shear centre, shear area and maximum shear stress.
 - For sections comprising more than one element, the same E value must be assumed for the whole of the section.
 - The section may include any number of voids subject to the limitations of module S.01, except for shear calculations, where no voids are permitted.
- The defined section may have sides designated as "continuous", for example, break lines within a continuous slab.

Section Design Modules for British Standards: S.02_{BS}, S.04_{BS}, S.05_{BS} and S.07_{BS}

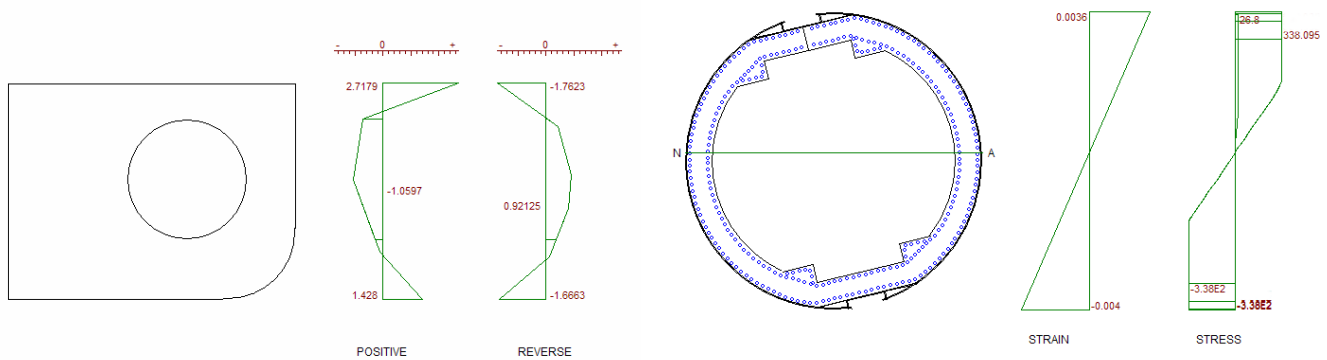

This is a set of four modules for code checking reinforced concrete sections

S.02 – Differential temperature analysis

S.04 – Design and assessment of concrete sections to BS 5400

S.05 – Design of concrete sections to BS 8110

S.07 – Early thermal cracking for concrete sections

The section outline, voids, reinforcement and material properties are all defined in module S.01.

These modules are used to enter loads, and to determine the effects of these loads on the section.

S.02 uses differential temperature gradient profiles to calculate relaxing moments and forces and self-equilibrating stresses.

S.04 and S.05 use strain compatibility to calculate the stresses and strains in the section arising from moments applied about the X and Y axes, and applied axial loads. They also calculate the available bending or axial load capacity. Crack widths are calculated where appropriate.

S.07 calculates the amount of reinforcement required to control early thermal cracking.

There are several benefits to these modules:

- ⇒ All numeric data is displayed graphically where possible, so that many errors of data entry are immediately obvious.
- ⇒ All results are displayed graphically, so that tables of numbers become meaningful pictures of results.
- ⇒ The graphical results for strain and stress profiles enable the engineering behaviour of sections to be more readily understood.
- ⇒ The modules use the same section data, so that changing between modules, changing loads and changing section outlines is completely seamless.
- ⇒ Interaction diagrams of moment and axial load are easily generated.
- ⇒ Wherever possible a mimic of an engineer's hand calculations are created, in order to allow the user to see why and how results are calculated. This allows the user to check the program, and to develop confidence in using it, as well as conforming to many quality standards that require a hard copy of the design calculations.

Module Specifications S.02 – Differential temperature analysis for any section

- For sections defined using module S.01:
 - Differential Temperature load case generator for:
 - BS 5400 Part 2 figure 9 (BD 37/88 figure 9 is identical)
 - BS 5400 Part 2 Appendix E (BD 37/88 Appendix E is identical)
 - Any temperature profile that can be defined by up to 20 temperatures within the depth of the section.
- Calculation of relaxing moments and self equilibrating stresses, using the method as described by Hambly ["Bridge Deck Behaviour", 2nd Edition, E & F N Spon, 1991].
- The calculations can be set to either ignore or include any reinforcement present

Module Specifications S.04 – Design and assessment of reinforced concrete sections

- For sections defined using module S.01 comprising concrete with reinforcement and/or pre-stressed tendons:
 - BS 5400 Part 4 Ultimate Limit state analysis to clause 4.5.2 & 5.5.
 - BS 5400 Part 4 Serviceability Limit state stress analysis to clause 4.5.1.
 - BS 5400 Part 4 Serviceability Limit state crack width calculation to clause 5.8.8.2 Equation 24 and Equation 26.
- Loading for the stress analysis may be any combination of axial load, bending about the global x axis, bending about the global y axis, applied strain plane.
- Any number of loading cases may be defined for a single section data set.
- Loading for the crack width calculation may be as for the stress analysis, except that applied strains may only be included where they do not affect the neutral axis angle when combined with the other loadings.
- The applied strain plane loading may be applied to any individual element of the section, thus enabling staged construction to be analysed.
- Loading options may be used to:
 - Specify M_x and/or M_y and/or N to calculate stresses and strains
 - Specify V_x and V_y to calculate shear reinforcement requirements in accordance with BS 5400 Part 4 or BD 44/95.
 - Find limiting capacity for section for
 - M_x or M_y or N; $-M_x$ or $-M_y$; M_y and M_x
 - N and M_x or N and M_y
 - Specify some loads as first option, and find additional loads as second option, which load section to its capacity
- Fully detailed hand calculation style output is produced for the crack width and shear calculations.
- Interaction curves may be plotted for any combination of axial load N, and moments M_x , M_y
- BD 44/95 crack width option is provided
- Check for tensile failure (clause 5.3.2.1 & 6.3.3.1) is included in the output.
- The clauses referred to above are unaffected by the HA implementation of BS 5400 Part 4 (BD 24/92).
- For assessments to BD 44/95:
 - Check for tensile failure may be ignored.
- Material strengths and partial factors are user controlled parameters.

Module Specifications S.05 – Design of concrete sections to BS 8110

- For sections defined using module S.01 comprising concrete with reinforcement and/or pre-stressed tendons:
 - BS 8110 Part 1 Ultimate Limit state analysis to clause 3.4.4.1 & 3.8.4.1
 - BS 8110 Part 2 Serviceability Limit state stress analysis to clause 3.6, Figure 3.1
 - BS 8110 Part 2 Serviceability Limit state crack width calculation to clause 3.8.3
 - BS 8110 Part 2 Serviceability Limit state curvature and deflection calculations to clause 3.6 Equation 7 and 3.7 Equation 11.
- Loading for the stress analysis may be any combination of axial load, bending about the global x axis, bending about the global y axis, applied strain plane.
- Any number of loading cases may be defined for a single section data set.
- Loading for the crack width calculation may be as for the stress analysis, except that applied strains may only be included where they do not affect the neutral axis angle when combined with the other loadings.
- The applied strain plane loading may be applied to any individual element of the section, thus enabling staged construction to be analysed.
- Loading options may be used to:
 - Specify M_x and/or M_y and/or N to calculate stresses and strains
 - Specify V_x and V_y to calculate shear reinforcement requirements
 - Find limiting capacity for section for
 - M_x or M_y or N; $-M_x$ or $-M_y$; M_y and M_x
 - N and M_x or N and M_y
 - Specify some loads as first option, and find additional loads as second option, which load section to its capacity
- Fully detailed hand calculation style output is produced for the crack width, shear, curvature and deflection calculations.
- Interaction curves may be plotted for any combination of axial load N, and moments M_x , M_y

Module Specifications S.07 – Early thermal cracking for reinforced concrete sections

- For sections defined using module S.01:
 - Calculation of the reinforcement required for the control of early thermal cracking in accordance with:
 - BS 5400 Part 4 clause 5.8.9 and BD 28/87 including Amendment 1 dated 1989
 - The distance from an external surface to the central core may be varied from the standard dimension of 250mm.
- The defined section may have sides designated as "continuous", for example, break lines within a continuous slab.